

**AKSA Power Generation** has been producing industrial generator sets with an innovative compact design and excellence in quality for over 30 years. AKSA has been providing reliable power through three main production plants and over 15 branch offices worldwide.

Alternator (125 °C Rise)	Voltage	Ph	Pf	Hz	Stand-by Ratings		Prime Ratings	
					kW/kVA	Amp	kW/kVA	Amp
PI144H Winding #311	480/277V	3	0.8	60	30/37	45	27/34	41
	440/254V	3	0.8	60	30/37	49	27/34	44
	240/139V	3	0.8	60	30/37	90	27/34	81
	240/120V	3	0.8	60	30/37	90	27/34	81
PI144H Winding #06	208/120V	3	0.8	60	30/37	104	27/34	94
	240/120V	1	1	60	30/30	125	27/27	113



## Rating Definition

**Stand-by Power (Maximum):** Power available at variable load in the event of main power network failure. **No over load is permitted.**

**Prime Power:** Power available at variable load in lieu of a main power network. Overload of 10% is permitted for 1 hour in every 12 hours of operation.

The above ratings represent the engine performance capabilities to conditions specified in accordance with ISO 8528/5 & ISO3046.

**Derating may be required for conditions outside of the test conditions.**

## Codes & Standards

### U.S.EPA

**EPA Certified Tier4 Interim** for Emergency Stationary Applications.



The Generator set is **UL2200 listed**. Dual wall **UL142** listed fuel tanks are also available.



The Generator set is designed and manufactured in a facility certified to **ISO9001** standards.



The Generator set is designed and manufactured in a facility certified to **ISO14001:2004** standards.



The Generator meets **NFPA70, 99, 110, 37** Level 1 when equipped with the necessary accessories and installed per NFPA standards.

## Standard Features

**AKSA Power Generation** provides **single source responsibility** for the generator set & accessories.

The generator set, with its components, are **prototype tested** and **production tested** according to the UL test program.

**John Deere heavy duty** four cycle industrial diesel engine delivers low emission, reliable power, fuel efficiency and fast response to load changes.

**Newage Stamford** industrial generators meet the requirements of BS EN 60034 and the relevant sections of other international standards such as BS5000, VDE0530, NEMA MG1-32, IEC34, CSA C22.2-100, AS1359.

**Non-proprietary NFPA110 compliant control system** provides total gen-set system integrated control, protections, metering, automatic starting/stopping with options of remote control, remote display or remote annunciation.

**Heavy duty base frame** with integral pad **vibration isolators** eliminates the need for under unit spring vibration isolators.

## Engine Data

Manufacturer	<b>John Deere</b>
Model	<b>3029TFG89</b>
Cylinders	3, In-line
Max. power @ rated rpm; kWm (BHP)	35 (47)
Brake mean effective pressure; kPa	714
Aspiration & Cooling	Turbo charged
Total displacement; L (in <sup>3</sup> )	2.9 (177)
Bore; in. (mm)	4.2 (106)
Stroke; in. (mm)	4.3 (110)
Compression ratio	17.2:1
Governor type	Mechanical
Engine crankcase vent system	Open

## Engine Electrical System

Charging alternator	12V, Negative Ground
Starter rolling current @32 °F; (amp)	640
Min. voltage at ECU during cranking; (dc)	6
Max. allowable start circuit resistance; (Ohm)	0.0012
Starter motor rated voltage; (dc)	12
Battery quantity x rating & CCA	1 x 54Ah, 410

## Fuel System

Combustion system	Direct injection
Fuel injection pump	Stanadyne DB2
Governor Type	Mechanical
Total fuel flow; lb/hr	209
Fuel temp rise, inlet to return; °C	17.8
Max fuel inlet temp; °C	80
Max fuel inlet restriction; in.H <sub>2</sub> O (kPA)	80 (20)
Max. fuel return pressure; in.H <sub>2</sub> O (kPA)	80 (20)
Fuel filter @98% efficiency	8 mic

## Fuel Consumption (gal/hr)

110% Load	2.60
100% Load	2.37
75% Load	1.83
50% Load	1.27

## Exhaust System

Exhaust gas flow; (m <sup>3</sup> /min)	8.3
Max. exhaust restriction; (kPa)	7.5
Max. exhaust gas temp; (°C)	580
Max. bending moment on turbo outlet; (lb-ft)	5.2

## Cooling System

Radiator ambient temp; °C (°F)	50 (122)
Engine coolant capacity; L	5.7
Min. coolant fill rate; L/min (gal/min)	11 (2.9)
Thermostat operation range; °C	82-94
Max top tank temp; °C	105
Min. limiting ambient temp; °C	47
Cooling fan type	Pusher
Min. pressure cap; (psi)	10
Combustion air flow; m <sup>3</sup> /min	3.6
Intake manifold pressure; (psi)	10.8
Engine coolant flow; L/min (gal/min)	110(29)
Engine heat rejection; BTU/min	1144
Air cleaner efficiency	99.9%

## Lubrication System

Oil pressure @rated speed; psi	48
Max. crankcase pressure; in. H <sub>2</sub> O (kPa)	2 (0.5)

## Alternator Data

Manufacturer	<b>Stamford</b>
Models	
Winding #311	<b>PI144H</b>
Winding #06 – Dedicated 1 phase	<b>PI144H</b>
Design	4 Pole, drip proof rotating field
Exciter type	Brushless, self excited EBS option is available
Stator	2/3 winding pitch
Rotor	Single bearing, flexible disc
Leads	
Winding #311	12
Winding #06	4
Voltage regulator	Solid state, Volts/Hz
Voltage regulation	Self excited 1%
Insulation	Class H
Temp. rise @ 40°C ambient	125°C Prime
150°C Standby	
Alternator Cooling	Direct drive Centrifugal Blower
Cooling air; m <sup>3</sup> /min 0.108	
Waveform distortion	No load < 1.5% Non-distorting balanced linear load <5%
Max. over-speed; rev/min	2250
Telephone influence factor (TIF)	<50
Telephone harmonic factor (THF)	<2%
Sustained short circuit current 10sec with EBS fitted; (amp)	
Winding #311 – Star	191
Winding #311 – Parallel Star	382

## Locked rotor kVA (skVA) @30% voltage dip

	Self Excited
480/277V - 3ph	84
208/120V - 3ph	56

## Control System



**DSE7320** is an advanced control system, suitable for a wide variety of single, diesel or gas, gen-set applications. Monitoring and an extensive number of engine parameters, the module displays warnings, shutdowns and engine status information on the back lit LCD screen, illuminated LEDs, remote PC and via SMS text alerts (with external modem).

- UL recognized, NFPA110 Level 1 compatible
- LCD text display, key menu navigation and front panel editing
- Off/Manual/Auto model switch
- Two wire starting/stopping in Auto mode
- Engine exerciser
- IP65 front panel rating with supplied sealing gasket
- Configurable 9 inputs, 8 outputs with expansion capability
- Real time clock provides accurate event logging
- Fully configurable via DSE Configuration Suite PC software
- Remote SCADA monitoring and BMS integration features
- License free PC software

### Protections

- Gen. Voltage - under/over
- Gen. Frequency - under/over
- Engine Speed - under/over
- Engine Oil pressure - low
- Engine Temp. - low/high
- Battery Voltage - low/high
- Weak battery
- Fail to start/stop
- Charge fail
- Over current & load(kW/kVAr)
- Unbalanced load
- Independent Earth Fault
- Reverse Power
- Fuel level - low/high (optional)
- Loss of speed signal

### Instruments

- Gen. Voltage (L-L/L-N)
- Gen Frequency
- Engine Speed
- Oil Pressure
- Water Temperature
- Battery Voltage
- Run time
- Engine maintenance due
- Phase sequence
- Pwr. monitoring (kWh / kVAh / kVArh)
- Power (kW/kVA/kVAr)
- Power factor
- Gen. Current (L1-L2-L3)
- Earth current

## Standard Features & Accessories

- UL2200 Listing
- Sound Attenuated Steel Enclosure
- 150mph Wind Rating
- Heavy Duty Steel Base-frame
- Anti-vibration pads
- Residential Grade Silencer Inside Enclosure
- Flex Fuel Lines
- Oil Drain Valve & Extension
- Emergency Stop Switch
- Battery, Battery Rack & Cables
- Battery Charger (4 Amp)
- Main Line CB (80% rated)
- Jacket Water Heater (500W)
- Operations Manual
- 2 Years / 2000hours Limited Warranty

## Optional Accessories

- Upsized Alternator
- PMG Excitation
- Alternator Anti-condensation Heater
- Manual Speed Adjust
- Sub Base Fuel Tank (UL142 / UL2085)
- Low Fuel & Fuel Leak Alarms
- Fuel Level Monitoring on Controller & High Fuel Alarm
- Spring Anti-vibration pads
- Critical Grade Silencer
- Fuel Line Check Valve
- Oil Temperature Gauge
- Remote Emergency Stop Switch
- Battery Restraint
- Battery Charger 10/20Amp per NFPA110
- Main Line CB (100% rated)
- Main Line CB Shunt Trip
- Remote Serial Display Panel
- Remote Annunciation Panel (8/16/24 lights)
- 5 Years / 2000hours Limited Warranty

## Dimensions & Weight & Sound Level

### Gen-set Without Fuel Tank

	Open Type	Enclosed Type
L (in.)	72	89
W (in.)	40	40
H (in.)	44	67
Weight (lb)	1450	1950
Sound Level (dBA@23ft)		69

### Fuel Tank – UL142

	24h(65gal)	48h(130gal)	72h(190gal)
L (in.)	112	112	112
W (in.)	40	40	40
H (in.)	9	15	20
Weight (lb)	850	1030	1200

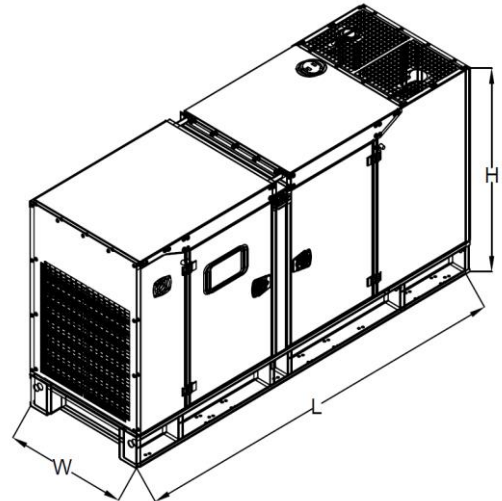

\*Manufacturer reserves the right to make changes in model, technical specifications, color, equipment and accessories without prior notice.



**AKSA POWER GENERATION USA LLC**  
371 Exchange Street, West Monroe, LA 71292

Tel: 318.855.8377

Fax: 318.855.8381

E-mail: sales@aksausa.com

AKSA Power Generation USA is a member of



**KAZANCI HOLDING**