

AKSA Power Generation has been producing industrial generator sets with an innovative compact design and excellence in quality for over 30 years. AKSA has been providing reliable power through three main production plants and over 15 branch offices worldwide.

Alternator (125 °C Rise)	Voltage	Ph	Pf	Hz	Stand-by Ratings		Prime Ratings	
					kW/kVA	Amp	kW/kVA	Amp
	480/277V	3	0.8	60	2000/2500	3007	1800/2250	2706
P1734E	460/265V	3	0.8	60	1980/2475	3106	1782/2227	2796
Winding #312	440/254V	3	0.8	60	1940/2425	3182	1746/2182	2864
	416/240V	3	0.8	60	1820/2275	3157	1638/2047	2842

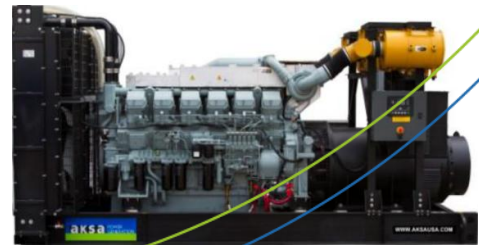

Rating Definition

Stand-by Power (Maximum): Power available at variable load in the event of main power network failure. **No over load is permitted.**

Prime Power: Power available at variable load in lieu of a main power network. Overload of 10% is permitted for 1 hour in every 12 hours of operation.

The above ratings represent the engine performance capabilities to conditions specified in accordance with ISO 8528/5 & ISO3046.

Derating may be required for conditions outside of the test conditions.

Codes & Standards

U.S.EPA

EPA Certified Tier2 for Emergency Stationary Applications.



The Generator set is **UL2200 listed**. Dual wall **UL142** listed fuel tanks are also available.



The Generator set is designed and manufactured in a facility certified to **ISO9001** standards.



The Generator set is designed and manufactured in a facility certified to **ISO14001:2004** standards.



The Generator meets **NFPA70, 99, 110, 37** Level 1 when equipped with the necessary accessories and installed per NFPA standards.

Standard Features

AKSA Power Generation provides **single source responsibility** for the generator set & accessories.

The generator set, with its components, are **prototype tested** and **production tested** according to the UL test program.

Mitsubishi Heavy Duty four cycle industrial diesel engine delivers low emission, reliable power, fuel efficiency and fast response to load changes.

Newage Stamford industrial generators meet the requirements of BS EN 60034 and the relevant sections of other international standards such as BS5000, VDE0530, NEMA MG1-32, IEC34, CSA C22.2-100, AS1359.

Non-proprietary, NFPA110 compliant control system provides total gen-set system integrated control, protections, metering, automatic starting/stopping with options of remote control, remote display or remote annunciation.

Heavy duty base frame with integral pad **vibration isolators** eliminates the need for under unit spring vibration isolators.

Engine Data

Manufacturer	Mitsubishi
Model	S16R-Y2PTAW2-1
Cylinders	16, 60 °V
Max. power @ rated rpm; kWm (BHP)	2180 (2923)
Brake mean effective pressure; Psi	323
Aspiration & Cooling	Turbo charged
Total displacement; L (in ³)	65.37 (3989)
Bore; in. (mm)	6.69 (170)
Stroke; in. (mm)	7.09 (180)
Compression ratio	14.0:1
Governor type	Electronic, ±0.25
Rated rpm	1800
Rotation	Anti-clockwise viewed on flywheel

Engine Electrical System

Charging alternator	24V, Negative Ground
Alternator rating; (Ah)	30
Starter motor power; (kW)	7.5 x 2
Starter motor rated voltage; (dc)	24
Battery quantity x rating & CCA	4 x 200Ah, 1150

Fuel System

Injector System	Mitsubishi PS8 Type x 2
Fuel supply connection size	5/8" NPT
Fuel return connection size	5/8" NPT
Max. fuel lift; m (ft)	3 (9.84)
Max static head of return pipe; mmHg	150
Fuel filter & water separator	Available

Fuel Consumption (gph)

110% Load	160.0
100% Load	141.0
75% Load	106.2
50% Load	71.4
25% Load	40.5

Exhaust System

Exhaust gas flow; (m ³ /min)	544
Max. back pressure; mm H ₂ O	600
Exhaust outlet size; (mm)	202

Cooling System

Radiator ambient temp; °C (°F)	50 (122)
Coolant capacity-engine only; L (gal)	170 (44.9)
Max external friction head at engine outlet; Psi	5.0
Coolant pump drive	Gear
Thermostat operation range; °C	71-85
Max coolant temp @ engine outlet of jacket; °C	98
Cooling fan type	Pusher
Intake air flow; m ³ /min	206
Engine coolant flow; Gpm	489
Energy to coolant; BTU/min	44374
Energy to ambient; BTU/min	10240
Energy to air cooler; BTU/min	44374
Air filter	Paper element

Lubrication System

Oil capacity; L (gal)	230 (60.8)
Oil capacity of standard pan	
High; L (gal)	200 (53)
Low; L (gal)	140 (37)
Oil cooler	Water cooled
Oil pressure at rated speed; Psi	71 ~ 93
Oil temp (continuous operation); °C	110

Alternator Data

Manufacturer	Stamford
Model	PI734E
Design	4 Pole, drip proof rotating field
Exciter type	P.M.G.
Stator	2/3 winding pitch
Rotor	Single bearing, flexible disc
Leads	6
Efficiency	
480V	95.9
416V	95.7
Voltage regulator	Solid state, Volts/Hz
Voltage regulation	
PMG	0.5%
Insulation	Class H
Protection	IP23
Temp. rise @ 40°C ambient	125°C Prime 150°C Standby
Alternator Cooling	Direct drive centrifugal blower
Cooling air; m ³ /min	0.8
Waveform distortion	No load < 1.5%
	Non-distorting balanced linear load < 5%
Max. over-speed; rev/min	2250
Telephone influence factor (TIF)	< 50
Telephone harmonic factor (THF)	< 2%
Sustained short circuit current 10sec; (amp)	
Star (WYE)	7500

Locked rotor kVA (skVA) @30% voltage dip

	PMG Excited
480/277V - 3ph	4600
416/240V - 3ph	3100

Control System



DSE7320 is an advanced control system, suitable for a wide variety of single, diesel or gas, gen-set applications. Monitoring and an extensive number of engine parameters, the module displays warnings, shutdowns and engine status information on the back lit LCD screen, illuminated LEDs, remote PC and via SMS text alerts (with external modem).

- UL recognized, NFPA110 Level 1 compatible
- LCD text display, key menu navigation and front panel editing
- Off/Manual/Auto model switch
- Two wire starting/stopping in Auto mode
- Engine exerciser
- IP65 front panel rating with supplied sealing gasket
- Configurable 9 inputs, 8 outputs with expansion capability
- Real time clock provides accurate event logging
- Fully configurable via DSE Configuration Suite PC software
- Remote SCADA monitoring and BMS integration features
- License free PC software

Protections

- Gen. Voltage - under/over
- Gen. Frequency - under/over
- Engine Speed - under/over
- Engine Oil pressure - low
- Engine Temp. - low/high
- Battery Voltage - low/high
- Weak battery
- Fail to start/stop
- Charge fail
- Over current & load(kW/kVA_r)
- Unbalanced load
- Independent Earth Fault
- Reverse Power
- Fuel level - low/high (optional)
- Loss of speed signal

Instruments

- Gen. Voltage (L-L/L-N)
- Gen Frequency
- Engine Speed
- Oil Pressure
- Water Temperature
- Battery Voltage
- Run time
- Engine maintenance due
- Phase sequence
- Pwr. monitoring (kWh / kVAh / kVA_rh)
- Power (kW/kVA/kVA_r)
- Power factor
- Gen. Current (L1-L2-L3)
- Earth current

Standard Features & Accessories

- UL2200 Listing
- Sound Attenuated Steel Enclosure
- Canopy DC lights
- Heavy Duty Steel Base-frame
- Anti-vibration pads
- Residential Grade Silencer Inside Enclosure
- Flex Fuel Lines
- Oil Drain Valve & Extension
- Emergency Stop Switch
- Battery, Battery Rack & Cables
- Battery Charger (2.5 Amp)
- Main Line CB (80% rated)
- Jacket Water Heater (2 x 4000W)
- Operations Manual
- 2 Years / 2000hours Limited Warranty

Optional Accessories

- Upsized Alternator
- Alternator Anti-condensation Heater
- Manual Speed Adjust
- Sub Base Fuel Tank (UL142 / UL2085)
- Low Fuel & Fuel Leak Alarms
- Fuel Level Monitoring on Controller & High Fuel Alarm
- Spring Type Anti-vibration pads
- Critical Grade Silencer
- Fuel Line Check Valve
- Oil Temperature Gauge
- Remote Emergency Stop Switch
- Battery Restraint
- Battery Charger 10/20Amp per NFPA110
- Main Line CB (100% rated)
- Main Line CB Shunt Trip
- Remote Serial Display Panel
- Remote Annunciation Panel (8/16/24 lights)
- 5 Years / 2000hours Limited Warranty

Dimensions & Weight & Sound Level

Gen-set Without Fuel Tank

Type	Open	Enclosed
L (in.)	231	480
W (in.)	86	96
H (in.)	108	114
Weight (lb)	29650	62850
Sound Level (Estimated dBA@23ft)		84

Fuel Tank – UL142

	24h(3840gal)
L (in.)	500
W (in.)	107
H (in.)	28
Weight (lb)	11800

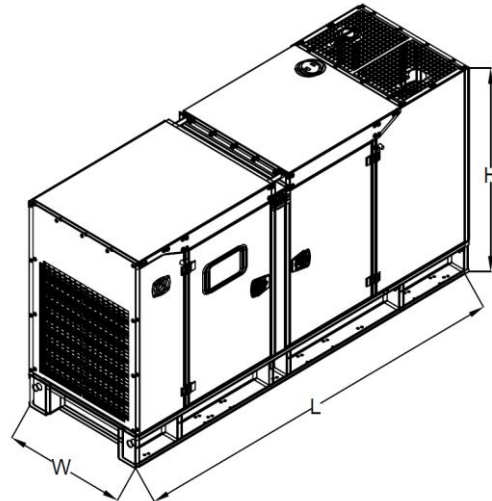

*Manufacturer reserves the right to make changes in model, technical specifications, color, equipment and accessories without prior notice.



AKSA POWER GENERATION USA LLC
 371 Exchange Street, West Monroe, LA 71292
 Tel: 318.855.8377
 Fax: 318.855.8381
 E-mail: sales@aksausa.com
 AKSA Power Generation USA is a member of

